

VERSALIFT

VTL135 EVO

Van mounted telescopic platform



Available for class B driving licence



EVO controls



Emergency lowering controls at the pedestal



Turret tailswing within the mirrors



No outriggers for quick setup & packing



VERSALIFT

A **TIME** MANUFACTURING COMPANY

VTL135 EVO - Renault Master / Nissan NV400 / Opel Movano



More payload for workshop, parts and tools

Manufactured from 1.5mm thick ultra-high strength steel

Added stability delivering smooth and steady working conditions

■ Length: 6,857 mm ■ Height: 3,300 mm ■ Wheelbase: 3,682 mm



Diagramme(s)

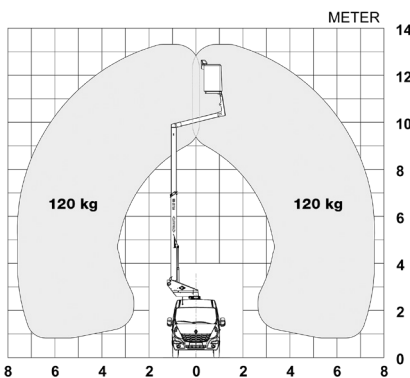

Options

- Workshop interior
- LED ceiling lights (in the load area)
- Tow bar
- Safety stripes (red/white)
- Plastic toolbox for the bucket
- Removable LED spotlight
- Power pack
- Sliding work table for the bucket



The shaped profile ultra high strength steel booms provide improved rigidity, stiffness and performance



Turret/knuckle tail swing within the mirrors



Workshop interior (optional)



EVO: Fixed outreach and 1 action at a time

Notes

Technical information is subject to change without prior notice. Images may show optional equipment. Installations and/or options may not be available in your specific region.

* Depending on the vehicle.

** Max payload with a driver, a passenger and a full tank of fuel (220 kg added to the installation weight).

Distributor

Versalift International
Soendervang 3, 9640 Farsøe
Denmark

+45 9863 2433
sales@versalift.dk
versaliftinternational.com