

Technische fiche :

100 VJR



 **MANITOU**
HANDLING YOUR WORLD

Capacities		Metrisch
Working height	h21	9.85 m
Platform height	h7	7.85 m
Max. outreach		3.15 m
Overhang		6.67 m
Pendular arm rotation (bottom)		+70 °
Platform capacity	Q	200 kg
Turret rotation		350 °
Number of people (indoor / outdoor)		2 / 1
Weight and dimensions		
Platform weight*		2650 kg
Platform dimensions (length x width)	lp / ep	1.11 m x 0.93 m
Overall length	l1	2.80 m
Overall width	b1	0.99 m
Overall height	h17	1.99 m
Floor height (access)	h20	0.51 m
Jib length	l13	1.50 m
Counterweight offset (turret at 90°)	a7	0.09 m
External turning radius	Wa3	2.09 m
Ground clearance under pothole protection	m6	0.02 m
Ground clearance at centre of wheelbase	m2	0.09 m
Wheelbase	y	1.20 m
Performances		
Drive speed - stowed		5 km/h
Drive speed - raised		0.65 km/h
Gradeability		25 %
Permissible leveling		2 °
Wheels		
Tyres type		Solid non-marking tires
Standard tyres		406 x 127 mm
Drive wheels (front / rear)		0 / 2
Steering wheels (front / rear)		2 / 0
Braking wheels (front / rear)		0 / 2
Engine/Battery		
Electric engine power rating		2 x 1.50 kW
Number of hydraulic pump / Capacity of hydraulic pump		2 x 4.20 cm ³
Battery / Battery capacity		24 V / 250 Ah
Integrated charger (V / A)		24 V / 30 A
Miscellaneous		
Number of cycles with STD Battery (HIRD)		29
Ground Pressure		11.80 dan/cm ²
Hydraulic Pressure		140 bar
Hydraulic tank capacity		22 l
Vibration on hands/arms		< 2.50 m/s ²
Standards compliance		
This machine is in compliance with:		European directives: 2006/42/EC- Machinery (revised EN280:2013) - 2004/108/EC (EMC) - 2006/95/EC (Low voltage)

*Varies according to options and standards of the country to which the machine is delivered

100 VJR - Lastendiagram

Load Chart for MEWP Metric



100 VJR - Tekening met afmetingen

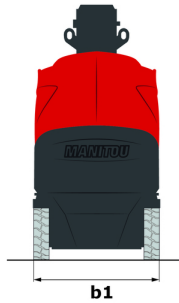
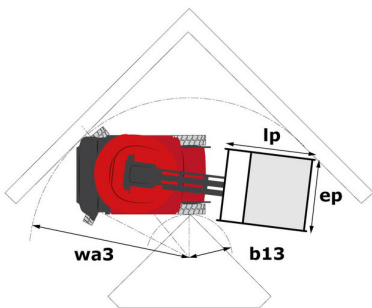

Uitrusting

Standaard

Audible alarm and illuminated indicator lamp (leveling, overload, lowering)

Battery charge indicator lamp

CAN bus technology

Emergency stop button in platform and on frame

Fixed pothole protection

Fork pockets

Hom in the platform

Hour meter

Integrated diagnostic assistance

Manual emergency lowering

Multi-voltage integrated charger

Negative-type braking on rear wheels

Non-marking rubber tyres

Pendular arm

Platform with open-work floor

Proportional controls

Slings and securing rings

Tool box in platform

Traction battery

Optioneel

110 or 230V plug with differential circuit breaker

230V Predisposition

Beep on every movement

Biodegradable oil

Centralized recharging of battery

Cold weather protection oil

Lights

Maintenance-free battery

Personalized paintwork

SMS : Safe Man System

Safety harness

Working headlight in platform



 **MANITOU**
HANDLING YOUR WORLD

Hoofdkantoor

B.P. 249 - 430 rue de l'Aubinière

44150 Ancenis Cedex - Frankrijk

Tel.: 00 33 (0)2 40 09 10 11 - Fax: 00 33 (0)2 40 09 10 97

www.manitou.com



Deze brochure beschrijft versies en configuratie-opties voor Manitou-producten die met verschillende apparatuur kunnen worden uitgerust. De uitrusting die in deze brochure wordt beschreven, kan standaard, optioneel of niet leverbaar zijn, afhankelijk van de uitvoering. Manitou behoudt zich het recht voor om de weergegeven en beschreven specificaties op elk moment en zonder kennisgeving vooraf te wijzigen. De fabrikant is niet aansprakelijk voor de gegeven specificaties. Neem voor meer informatie contact op met uw Manitou-dealer. Niet-contractueel document. De productbeschrijvingen kunnen afwijken van de werkelijke producten. De lijst met specificaties is niet allesomvattend. De logo's en visuele identiteit van het bedrijf zijn eigendom van Manitou en mogen niet zonder toestemming worden gebruikt. Alle rechten voorbehouden. De foto's en diagrammen in deze brochure zijn uitsluitend bedoeld voor raadpleging en informatie.

MANITOU BF SA - Naamloze vennootschap met raad van bestuur - Aandeelkapitaal: 39.668.399 euro - 857 802 508 RCS Nantes