

Features

STANDARD FEATURES

MEASUREMENTS

- 3,000 kg (6,613.2 lb) maximum lift capacity
- 6.90 m (22 ft 8 in) maximum lift height
- 3.9 m (12 ft 9 in) maximum forward reach

PRODUCTIVITY

- 4 x 4
- 4 - wheel steer
- 3 steering modes:
 - front wheel steer
 - crab steer
 - coordinated steer
- Power assisted steering
- Hydrostatic transmission with variable displacement pump and motor
- Two-speed mechanical gearbox
- Electro-proportional 4x1 joystick
- Limited slip differential on front axle
- Floating forks
- Attachment holder plate with hydraulic coupling
- Door with two sections: steel at bottom, glass on top. Both sections open separately
- Boom length and boom angle indicators correspond to the load charts
- Adjustable suspended seat
- Large diameter steering wheel
- Front and rear windscreen wipers
- Sunshield
- Roof protection grid inside cabin
- Front & rear lights
- Side-mounted engine for easy access to components
- Oil immersed multi-disc brake on front axle
- Lockable fuel tank
- Longitudinal stability control system with load monitor
- Visible display with coloured LEDs
- Audible alarm
- Automatic lock-out of boom extension and lowering
- Maintenance collar

POWER

- Deutz Turbo Diesel 91 hp (68 kW)

TYRES

- 405/70-20" PR14. 8 holes wheel disc (DIN 70361)



OPTIONS & ACCESSORIES

PRODUCTIVITY

- Air conditioning
- Second hydraulic line on boom
- Additional armrest
- Windshield protection grid
- Additional rear view mirror
- Adjustable spotlight
- Special air filter
- Hydraulic quick coupling for attachments
- Concrete mixing bucket pre-arrangement
- Electric pre-arrangement on boom
- Hydraulic inching
- 6-ton towing hitch
- 10-ton hydraulic jack and 24 mm wheel nut wrench
- Spare wheel

ATTACHMENT OPTIONS

- Loading shovel 800 L
- Light material loading shovel 1200 L
- Concrete bucket, manual/ hydraulic discharge 500 L
- Concrete mixing bucket with remote control 250 L
- Forks side-shift (+/- 100 mm)
- FEM 3 plate and forks kit
- Fixed hook on plate
- 2 m jib, 2,000 kg capacity
- 4 m jib, 900 kg capacity
- 4 m jib with 900 kg capacity hydraulic winch
- Brick-holder basket

UK

Millennium House
Brunel Drive
Newark NG24 2DE
UK
Tel: +44 (0)1476 584333
Fax: +44 (0)1476 584334

France

10, ZA de la Croix St. Mathieu
28320 Gallardon
France
Tel: +33 (0)2 37 26 09 99
Fax: +33 (0)2 37 26 09 98

Germany

Finienweg 3
28832 Achim/Bremen
Germany
Tel: +49 (0)4202 8852-0
Fax: +49 (0)4202 8852-25

Spain

Gaià 31, Pol. Ind. Plá d'en Coll
08110 Montcada i Reixac
Barcelona
Spain
Tel: +34 93 572 50 90
Fax: +34 93 572 50 91

Scandinavia

Importgatan 17
422 46 Hisings Backa
Sweden
Tel: +46 31 57 51 00
Fax: +46 31 57 90 20

Middle East

Terex Middle East
PO Box 282325, Dubai
U.A.E.
Tel: +971 4 339 1800
Fax: +971 4 339 1802
Email: InfoME@terex.com

Genie United States

18340 NE 76th Street
P.O. Box 97030
Redmond, WA
USA 98073-9730
Tel: +1 425 881-1800
Fax: +1 425 883-3475

Email: AWP-InfoEurope@terex.com

Distributed By:

COMPACT ROUGH TERRAIN TELEHANDLER

GTH™-3007



Specifications

MODEL		GTH™-3007	
MEASUREMENTS		Metric	Imperial
Lifting height maximum		6.90 m	22 ft 8 in
Lifting capacity maximum		3,000 kg	6,613 lbs
Lift capacity at maximum height		2,500 kg	5,511 lbs
Lift capacity at maximum reach		1,250 kg	2,755.5 lbs
Forward reach maximum		3.99 m	13 ft 1 in
Reach at maximum height		76 cm	2 ft 6 in
A Height		2.07 m	6 ft 9 in
B Height at steering wheel		1.35 m	4 ft 5 in
C Width		1.99 m	6 ft 6 in
D Inside cab width		75 cm	2 ft 5 in
E Track		1.59 m	5 ft 3 in
F Wheelbase		2.66 m	8 ft 8 in
G Overall length		5.91 m	19 ft 5 in
H Length at fork-holder plate		4.71 m	15 ft 5 in
I Ground clearance		50 cm	1 ft 8 in
M1 Obstruction angle		90°	90°
M2 Departure angle		50°	50°

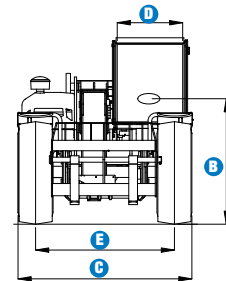
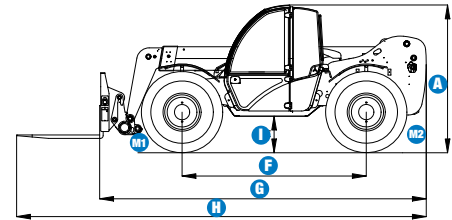

PRODUCTIVITY		
Inside/outside turning radius	2.2 m/3.8 m	7 ft 3 in/ 12 ft 6 in
Break out force (with 800L shovel SAE J 732/80)	4,270 kg	9,413 lbs
Towing capacity at dynamometer	5,200 kg	11,463 lbs
Travel speed maximum	32 km/h	17 mph
Fork-holder plate rotation	128°	128°
Floating forks	Length 1240 mm Section 100 x 50 mm	Length 49 in Section 4 in x 2 in
Tyres (DIN 70361)	405/70-20" PR14 8 holes wheel disc	
Lifting/lowering speed	9 sec./7 sec.	9 sec./7 sec.
Extension/retraction speed	8 sec./5 sec.	8 sec./5 sec.

POWER		
Engine	Deutz TD2011 L04W 4-cylinder Turbo Diesel 91 hp (68 kW), Tier 3	
Tank capacities		
Fuel	90 L	20 gal
Engine oil	10 L	2 gal
Hydraulic oil	80 L	17.5 gal
Hydraulic output/pressure	87 L/min-280 bars	19 gal/min-4,061 psi

WEIGHT		
Weight*	5,900 kg	13,006 lbs

STANDARD COMPLIANCE	
Operating cab conforms to ISO3471 (ROPS) and ISO3449 (FOPS)	
Low emission engine conforms to UE 97/68 directives.	
GOST R 50950-96	

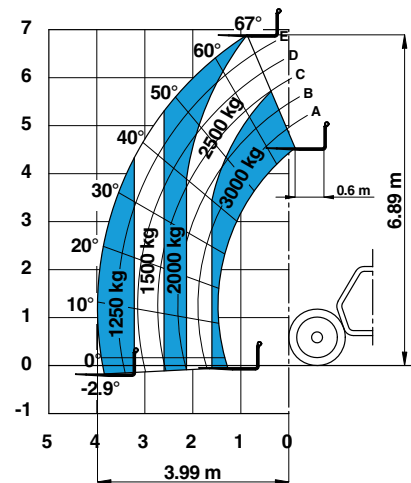

Lift capacity chart

EN1459, Annex B

* Weight will vary depending on options and/or country standards